

Anthony Medium RailTrac[®] Dump Through Liftgates[®]



*Lifting Capacities: 1,200 lb. 1,800 lb.
Lifting platform pivots to allow dumping of materials.*



ANTHONY
LIFTGATES, INC.[®]

Available Models, Platforms and Capacity

Model	Lifting Capacity (lbs.)	Bed Height Min-Max	Platform Load Area and Ramp	Outside Width	Approx. Shipping Wt. (lbs.)
AR-1200-78-DT	1,200	36"-52"	74" x 36"+6"	78"	783
AR-1200-90-DT	1,200	36"-52"	86" x 36"+6"	90"	802
AR-1200-94-DT	1,200	36"-52"	90" x 36"+6"	94"	814
AR-1800-90-DT	1,800	36"-58"	86" x 36"+6"	90"	822
AR-1800-94-DT	1,800	36"-58"	90" x 36"+6"	94"	834

All specifications subject to change without notice.

Standard Features and Specifications

- LIFETIME warranted slide runners – guarantees consistent, trouble-free service.
- Lifting platform pivots to allow dumping of materials.
- Lockable steel power unit enclosure – protects power pack from weather, theft, and vandalism.
- Pressure compensated flow valve – provides constant and controlled lowering speed, loaded or unloaded.
- 2+1 warranty – 2 years on mechanical components, 1 year on hydraulic system, parts and labor.
- Marine duty sealed toggle switch – operates reliably under all types of weather conditions.
- Closed hydraulic system – protects against outside dirt, moisture, & other contaminants.
- Circuit breaker – 150 Amp., protects against dead short in power cable.
- Chrome plated piston rod – keeps exposed surface free of rust and contamination to protect seals and extend service life.
- Low operating pressure (approx. 2300 psi) – increases life of components.
- EZ mount installation – shipped completely pre-assembled for fast, clean, easy installation.
- 12 volt DC drive.
- Relief valve – prevents overloading during lifting cycle.
- Factory installed hydraulic fluid – prevents contamination during installation and insures proper fluid.
- Spring-assist platform – provide easy opening and closing.
- Low profile platform – 2.5" thick
- Heavy-duty roller chain drive – provides long operating life and greater reliability than cable drive.
- Powder coated finish.
- POWER Up, GRAVITY Down; and spring assisted manual fold / unfold.
- Level ride platform – maintains ride that is level with rear of truck.
- Heat-shrink siliconed wire terminals and anti-rotation terminals – ensure positive electrical connections.
- Low pour (-70°) hydraulic fluid – excellent cold weather performance and long, trouble-free service.
- ZLC™ zero leak concept – uses machined fittings, SAE "O" rings and JIC hydraulic connections.
- Meets TMC electrical recommended practices.

Options

- Cab or ignition cut-off switch
- Hand-held control with plug and socket
- Taillight kits
- Auxiliary hand pump
- Street-side control
- Flush-mount inside van control
- Above bed-height models

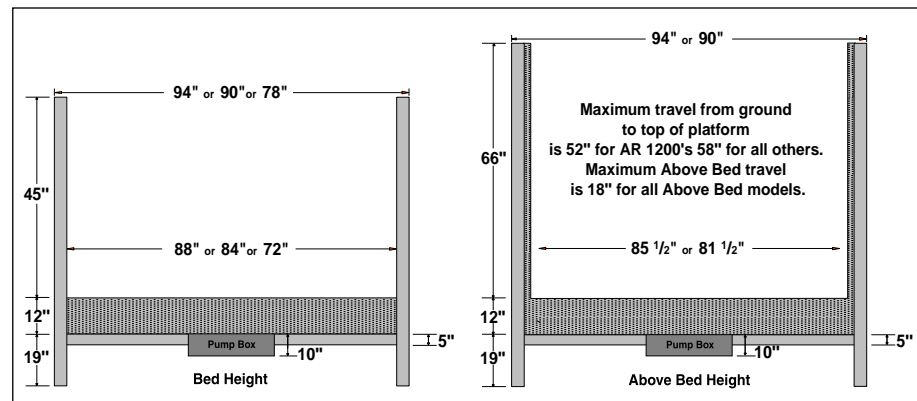

ANTHONY
LIFTGATES, INC.®

Anthony Liftgates, Inc.
1037 W. Howard Street
P.O. Box 615
Pontiac, IL 61764-0615
Phone: 815.842.3383
Fax: 815.844.3612
Toll Free: 800.482.0003
www.anthonyliftgates.com