

DISTRIBUTED BY:



Pro-Lift® T1400 PICKUP TRUCK CRANE

The Perfect Addition To Your Light Duty Utility Vehicle.

Lifting, loading, unloading and positioning becomes quick and easy. Great for jobs too heavy for manual lifting or too light for expensive rental equipment.

- 750 lb. capacity for ¾ to 1 ton pickups.*
- 500 lb. capacity for ½ ton pickups.*
- Manually extended 2 position folding boom.
- Manual rotation torque handle.
- Bi-directional 12 volt removable winch positively controls rate of descent.
- Easy grip remote control pendant allows operation from a safe distance.



Convenient knockdown style enhances driver vision and makes total use of available space.

WINCH SPECIFICATIONS:

- High torque motor
- Vented disk brake with double acting calipers.
- Coated contact tips.
- 30 AMP circuit breakers.
- 12' of ¼" aircraft cable.

CRANE SPECIFICATIONS:

- 54" stored height.
- 16" x 16" mounting base.
- 152 lbs.

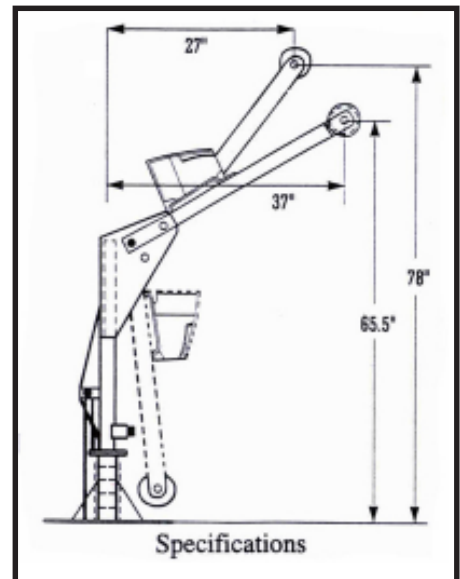

*Recommended lift capacities are only for the crane unit itself and not necessarily the capacity at which the crane should be operated. The crane capacity is limited by the condition of your vehicle and the method of installation and the supporting structure that has been added to the vehicle to spread the force of the loaded crane over as wide an area as possible.

DISTRIBUTED BY:



A DIVISION OF COLLINS ASSOCIATES, INC.
12110 BEST PLACE - CINCINNATI, OH 45241
SALES 800-226-2238 FAX 513-326-5427
www.venturo.com

SPECIFICATIONS SUBJECT TO CHANGE WITHOUT NOTICE.
PRINTED IN U.S.A.