

VENTURO

TRUCK MOUNTED CRANES

HT50KX & HT40KX

FULL HYDRAULIC TRUCK CRANES

50,000 FT/LB

40,000 FT/LB

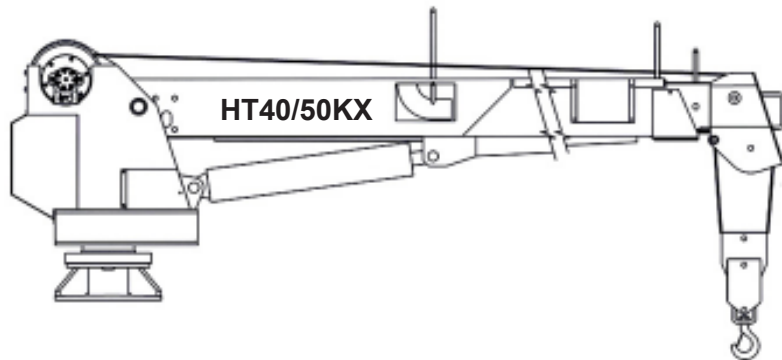

*Featuring Hydraulically
Powered Rotation, Elevation,
and Extension.*

FEATURES

	<u>HT50KX</u>	<u>HT40KX</u>
◆ Lifting Capacity	8,000 lbs.	6,000 lbs.
◆ Crane Rating	50,000 ft/lbs.	40,000 ft/lbs.
◆ Boom Length 10 – 16 – 20 ft.		
	10 ft. primary boom with 6 ft. Hydraulic extension to 16 ft. and 4 ft. manual extension to 20 ft.	
◆ Winch – Full hydraulic high efficiency planetary winch with hydraulic brake valve and multi-disc wet brake with sprag.		
◆ 400° rotation.		
◆ Load Holding Counterbalance Valves on elevation and extension cylinders. (ANSI B30.5)		
◆ Remote Control Pendant – environmentally sealed switches with 25 ft. cord and quick disconnect plug.		
◆ Priority Flow Control Valves – elevation and extension cylinders.		

STANDARD EQUIPMENT

- ◆ Anti-Two Blocking (ANSI B30.5)
- ◆ Moment Overload Shut Off Sensor (ANSI B30.5)
- ◆ 100' of 3/8" diameter 7 x 19 galvanized aircraft wire rope (ANSI B30.5).
- ◆ Snatch Block with Swivel Hook Safety Latch. Sheave diameter 16 times wire rope diameter (ANSI B30.5).

LIFTING CAPACITY LBS.		
REACH	HT50KX	HT40KX
6'	8,000	6,000
7'	7,200	6,000
10'	5,000	4,400
16'	3,100	2,550
20'	2,500	2,000

OPTIONAL EQUIPMENT

- ◆ Proportional Valve Controls
- ◆ Pullout Outriggers Systems - Manual or Hydraulic
- ◆ Side and Fold Away Manual Outriggers
- ◆ Direct Mount Pump and Reservoir

MINIMUM REQUIREMENTS

- ◆ HT50KX - 19,000 GVWR Chassis
- ◆ HT40KX - 14,000 GVWR Chassis
- ◆ Outriggers - Curbside and Streetside
- ◆ PTO (hoses & fittings), Pump and Reservoir
- ◆ Tachometer & Throttle Control (*recommended*)



A DIVISION OF COLLINS ASSOCIATES, INC.
12110 BEST PLACE - CINCINNATI, OH 45241
www.venturo.com

SPECIFICATIONS SUBJECT TO CHANGE WITHOUT NOTICE.
PRINTED IN U.S.A.

**HT50KX - 10-16-20 BOOM
MAXIMUM CAPACITY CHART**

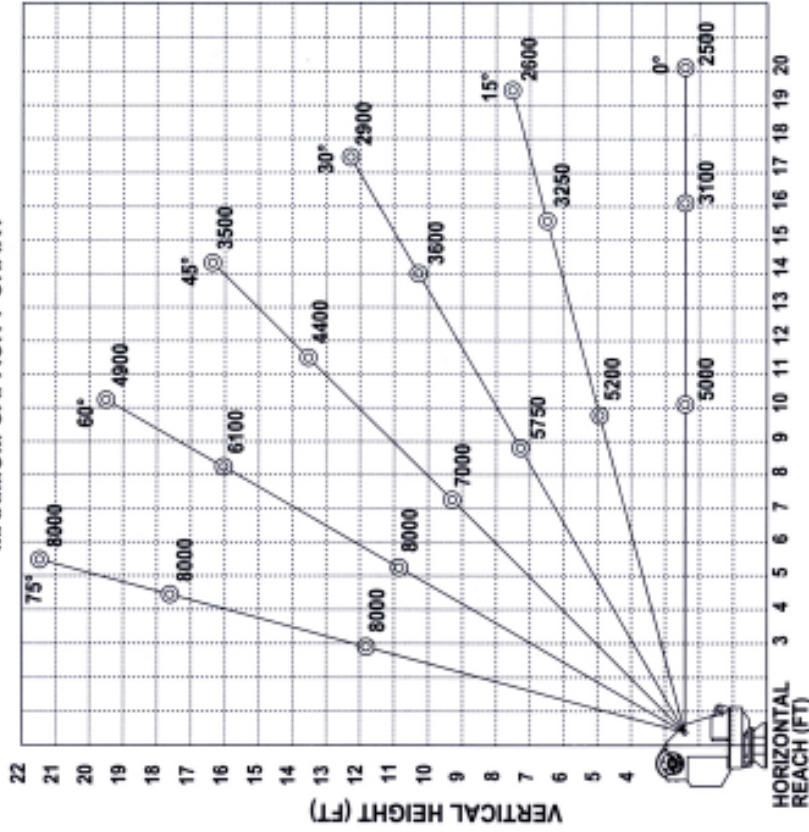

MUST USE SNATCH BLOCK
FOR LOADS OF 4000 LBS.
AND GREATER

**HT40KX - 10-16-20 BOOM
MAXIMUM CAPACITY CHART**

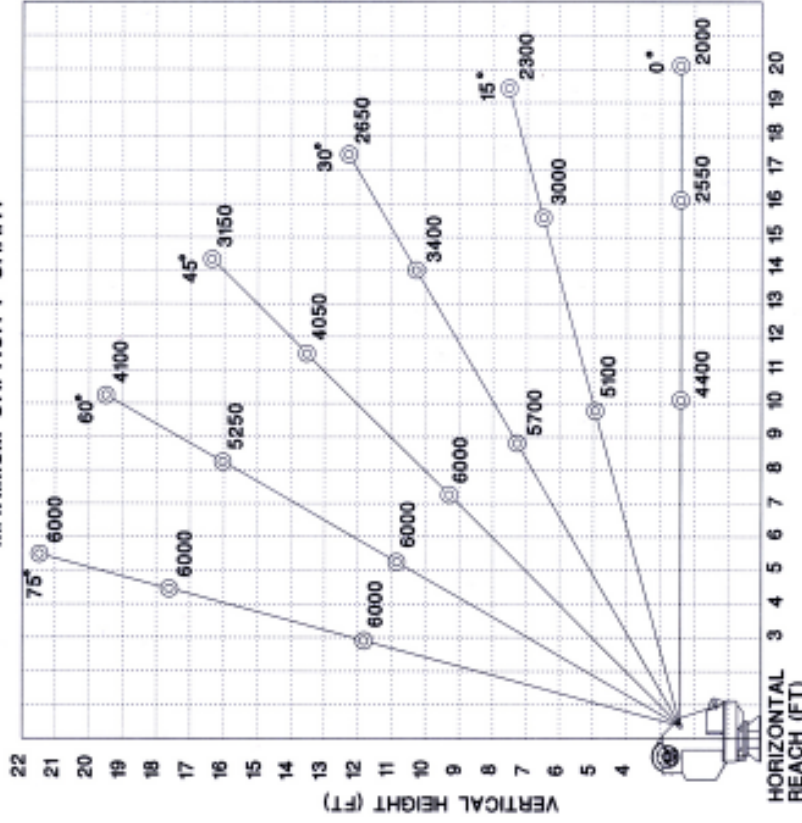

MUST USE SNATCH BLOCK
FOR LOADS OF 3000 LBS.
AND GREATER



VENTURO
MFG., INC.
CINCINNATI, OHIO

TITLE
CAPACITY CHART
HT50KX - 10-16-20

DATE
1-29-98B
REVISIONS
2-17-97A

SECTION
C-100
22351

TITLE
CAPACITY CHART
HT40KX - 10-16-20

DATE
1-29-98B
REVISIONS
2-17-97A

SECTION
C-100
22341