

Anthony Side-Mount TuckunderTM Hydraulic Liftgates[®]

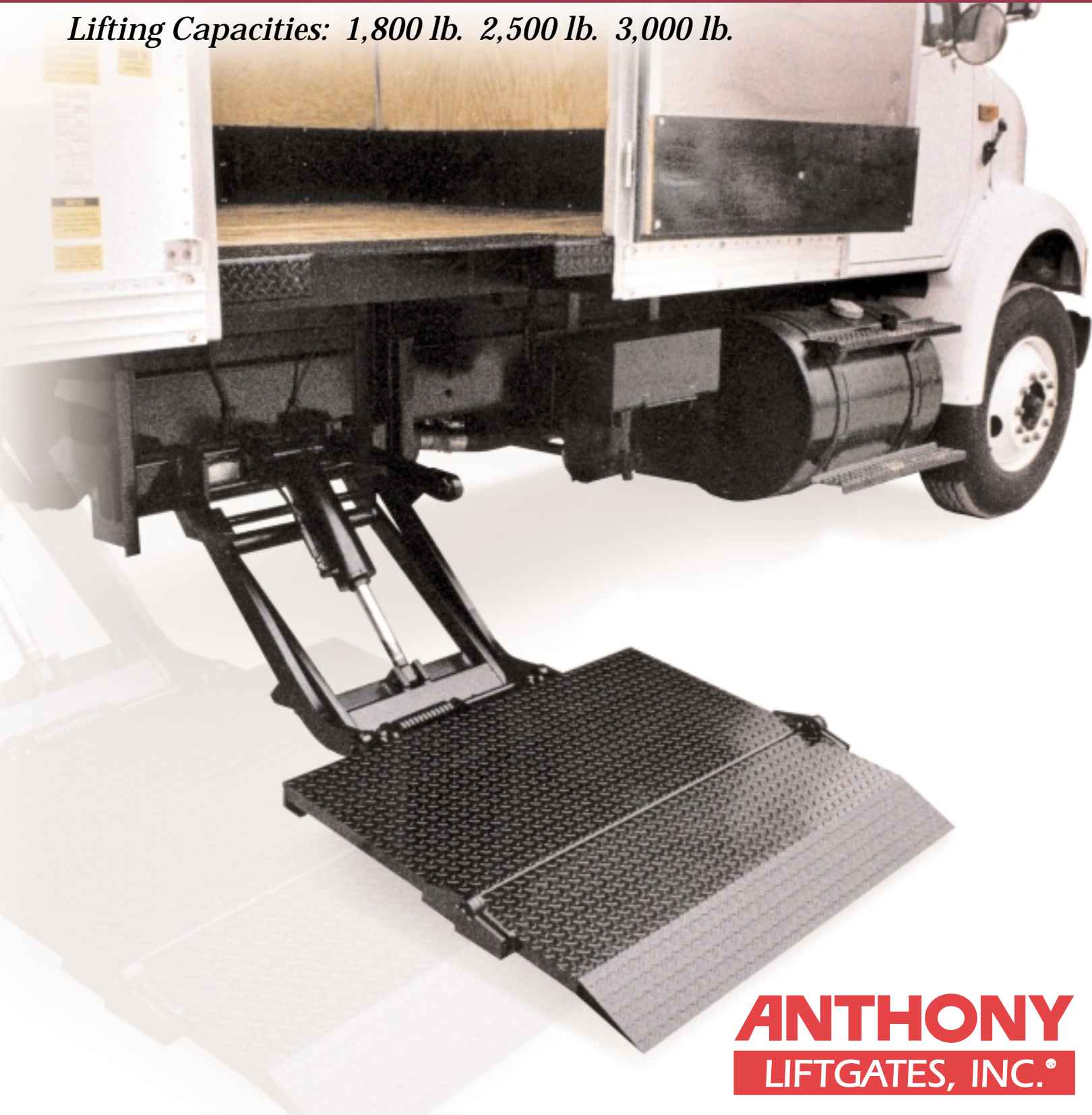

Lifting Capacities: 1,800 lb. 2,500 lb. 3,000 lb.



ANTHONY
LIFTGATES, INC.[®]

Available Models, Platforms and Capacities

Model	Lifting Capacity (lbs.)	Bed Height Min-Max	Platform Load Area and Ramp	Approx. Shipping Wt. (lbs.)	Approx. Install Hours
SM-1800-SF	1,800	42" - 57"	48" x 34" + 7"	720	12
SM-1800-SF	1,800	42" - 57"	72" x 34" + 7"	902	12
SM-2500-SF	2,500	42" - 57"	48" x 34" + 7"	732	12
SM-2500-SF	2,500	42" - 57"	72" x 34" + 7"	920	12
SM-3000-SF	3,000	42" - 57"	48" x 34" + 7"	746	12
SM-3000-SF	3,000	42"-57"	72" x 34" + 7"	934	12

Cannot be used with swing type doors.

All specifications subject to change without notice.

Standard Features and Specifications

- Special "Service-Free" bushings at major wear points; no grease zerks to service
- Low-pour hydraulic fluid for better cold weather performance
- Toggle switch control, stationary mount
- Galvanealed steel power pack enclosure
- Diamond tread platform surface
- Circuit breaker - 150 Amp.
- 3/16" thick diamond tread, 12" deep floor extension
- Silicone sealed heat shrink electrical connections
- Pressure compensated flow control valve
- Chrome plated piston rod
- 12 volt DC/hydraulic drive
- Meets TMC recommended practices
- Powder coated finish
- Master power disconnect (in cab)
- Yellow di-chromate plated pins used at all pivot points
- Pressure compensated flow valve to provide constant and controlled lowering speed.
- Relief valve prevents overloading during lifting cycle
- Piston cylinder wear rings to prevent scoring
- Platform roller wheel opener prevents metal-on-metal damage.
- Adjustable packing gland nut on cylinder allows adjustment of piston rod seal.
- EZ Mount installation, completely assembled
- Latch pin assembly to hold gate securely in closed position
- 3+2 warranty - 3 years on mechanical components, 2 years on hydraulic system, parts and labor
- Low operating pressure extends service life of power unit, hoses, cylinder seals, and battery

Options

- Hand-held control with plug and socket
- Flush-mount control inside van
- Lift-alert audible warning system
- Steel guard for toggle switch control box
- Recessed toggle switches
- P.T.O. Drive
- Custom platforms and applications
- 1/4" Heavy-duty floor extension

Side-Mount SM-Series Mounting Requirements

Floor Ht.	A	B
42" - 49"	19"	29 5/8"
50" - 51"	20"	28 3/4"
52" - 53"	21"	28"
54"	22"	27"

Maximum stock height 21"

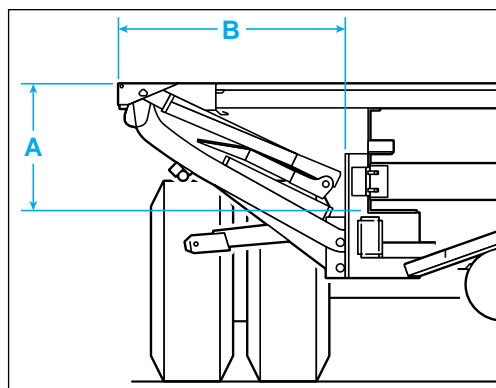

ANTHONY
LIFTGATES, INC.®

Anthony Liftgates, Inc.
1037 W. Howard Street
P.O. Box 615
Pontiac, IL 61764-0615
Phone: 815.842.3383
Fax: 815.844.3612
Toll Free: 800.482.0003
www.anthonyliftgates.com