

Anthony Magnum Tuckunder SF™

Hydraulic Liftgates®



Lifting Capacities: 3,000 lb. 4,000 lb.

- **GLR** – Gentle Level Ride system
- Large capacity 80" x 60" platform
- Power-up, power-down operation

Prepped with
Steel Shot Process



60"

80"

ANTHONY
LIFTGATES, INC.®

Anthony: Industry Leader

Anthony Liftgates has been the driving force in the industry since 1941, producing innovative designs and quality products for trucks of all sizes. Our factory support is unmatched in the industry, providing dealers and their customers coast to coast with prompt delivery of products, parts orders, and custom engineering requests. Looking for a product you can stake your reputation on? Anthony Liftgates offers a wide range of models backed by the best warranty in the business. For performance, dependability, and value, Anthony delivers the complete package for every application!

Hydraulic System

The **closed hydraulic system** protects against outside contaminants and moisture. The lockable **steel pump enclosure**



protects components from damage by impact, debris, and weather. Hingeless lid design eliminates corroded hinge problems.

LIFETIME WARRANTY Service-Free™ Bushings — An Anthony First

Used at critical pivot points,



these bushings extend pin and arm life, while eliminating routine lubrication and increasing resale value.

Anthony Exclusive, ZLC- Zero Leak Concept™

The use of machined fittings, SAE "O" ring and JIC hydraulic



connections, along with factory installed optimum cold weather hydraulic fluid, mean you'll have long, trouble-free service with no aggravating and costly leaks.

GLR – Gentle Level Ride

Wedge design platform tilts gently at the ground with smooth power-

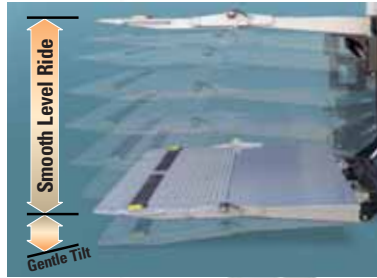

up / power-down horizontal lifting operation. Wide rollers under platform distribute weight to help eliminate parking lot dig-in .

E-Z Mount™ Installation

All Anthony MTU models are factory assembled, tested, and energized to assure the highest quality performance standards.



They ship completely assembled on skids for fast, clean, easy installation.

Positive Electrical Connections



Heat-shrink siliconed wire connections seal out moisture, and anti-rotation terminals insure rugged circuit protection.

Low Operating Pressure, Larger-Bore Hydraulic Cylinders

The double-weight hydraulic cylinders (mounted in our broad-arm design) allow operation at a lower pressure to

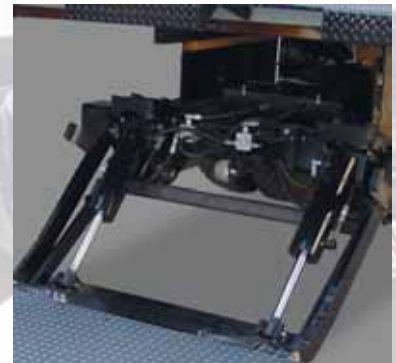

increase the life of the entire hydraulic system, batteries, and electrical components. The extra thick chrome plated piston rod and the piston cylinder wear rings further extend Service-Free operation

Choice of LVC or Potted Toggle Switch Control

Anthony's Low Voltage Control



has a program-mable security control, cycle counter, and alerts the operator when batteries are running low. The marine duty potted toggle switch permanently separates and seals all terminals and connections for the best all-weather protection.

Spring-Assist Platform: Aluminum Flip Over / Steel Main Section

Dual torsion springs provide easy opening and closing.

Heavy-Duty Sandwiched Hinge Plate

Maintains platform stability under heavy load conditions.

Wide Rollers Under The Platform

Distribute the weight to help eliminate parking lot dig-in.

Dual Driver Step Stirrups*

Provide convenient assistance for mounting and dismounting on left or right of truck.

Pressure Compensated Flow Valve

Provides constant and controlled lowering speed of the platform, loaded or unloaded, and prevents platform from "free-fall" under certain hydraulic failures.

Chrome Plated Piston Rod

Keeps exposed surface free from rust and contamination to protect seals and extend cylinder life.

Piston Cylinder Wear Rings

Prevent scoring by maintaining piston/cylinder wall tolerances.

Relief Valve

Prevents overloading during lifting cycle.

Low Operating Pressure

Extends service life of power unit, hoses, cylinder seals and battery.

1/4" Formed Diamond Tread Floor Extension

Provides rugged and attractive surface.

Power-Down Lowering

Consistent lowering speed in all temperature conditions.

Platform Roller Wheel Opener

Prevents metal-on-metal damage and provides smooth folding and unfolding.

**Shot Blast / Powder Coat**

All platforms and weldments are prepped with steel shot and then powder coated for a finish that provides the best surface appearance, impact resistance, coating adhesion, and wear resistance.

Proprietary Heat-Treated Adapter Frame Mechanism

Lifetime warranty against rotational wear failure – covers both parts and labor.

Exclusive 3 + 3 Warranty

3 years on mechanical structure, 3 years on electrical / hydraulic systems, parts and labor.

All Anthony Tuckunder liftgates are serial numbered and computer logged for quick factory service identification, warranty and repair information.

Maximum Duty Tubular Steel 2-Step Dock Bumpers

Thick tubular wall construction with 3"x 6" rubber dock bumper pads, designed and tested to withstand year after year of severe dock contact.

Circuit Protection

200 Amp. inline fuse protects truck wiring and power system in the event of a "dead short".

Cab Cut-Off Switch

Protects liftgate from unauthorized use.

Yellow Di-Chromate Plated Pins

Used at all pivot points for protection from rust, road salt, and moisture.

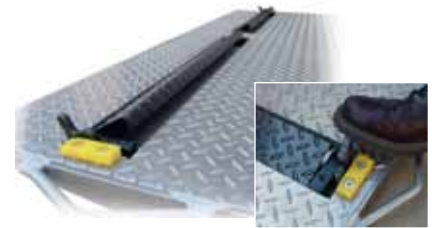

Pop-Up dual-split cart stops, foot operated. (standard)



Maximum Duty Tube Construction Dock Bumpers (standard)



Recessed Toggle Switch (optional)



Broad Arm Construction with steel main platform and aluminum flip-over, engineered for most efficient lifting geometry and proper distribution of loads



Super Safety Latch – the most positive in the industry

* NOTICE: Some models of Anthony Liftgates may be provided with step devices to assist the ingress and egress of the truck or trailer rear. These devices are NOT to be considered ALL INCLUSIVE of any requirements or guidelines regarding proper ingress and egress of trucks and trailers. These items are provided as only an added feature for installers to help simplify the meeting of possible ingress and egress requirements. As there are many variables in truck sizes and shapes, it is the installer's responsibility to determine proper ingress and egress requirements, such as steps and hand grips, for each vehicle receiving an Anthony liftgate.

Available Models, Platforms and Capacities

MODEL	Lifting Capacity (lbs.)	Bed Height Min-Max	Platform Load Area with Full Taper	Shipping Wt. (lbs.)
MTU-GLR-3	3,000	47"-57"	80" x 60"	1,659
MTU-GLR-4	4,000	47"-57"	80" x 60"	1,670

All models shipped with standard Gentle Level Ride platform.

Specifications subject to change without notice. Because we constantly strive to improve our products, some current models may vary slightly from photos shown.

Options

- Street-side control
- Flush-mount control inside van
- Lift-alert audible warning system
- Steel guard for toggle switch control box-standard on LVC control
- Recessed toggle switches
- Trailer mounting and wiring kits

- Wider floor extension for 102" wide body
- Wireless hand-held remote control
- Trail Charger Power Kit provides remote charging for liftgate batteries

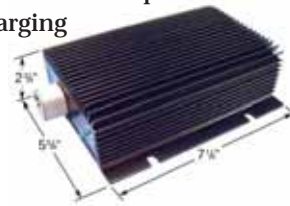

- Hand-held control with plug and socket



Mounting Requirements

A Bed Height	B Bottom of mounting plate to ground
47"	15 ³ / ₈ "
48"	16 ³ / ₈ "
49"	17 ³ / ₈ "
50"	18 ³ / ₈ "
51"	19 ³ / ₈ "
52"	20 ³ / ₈ "
53"	21 ³ / ₈ "
54"	22 ³ / ₈ "
55"	23 ³ / ₈ "
56"	24 ³ / ₈ "
57"	25 ³ / ₈ "

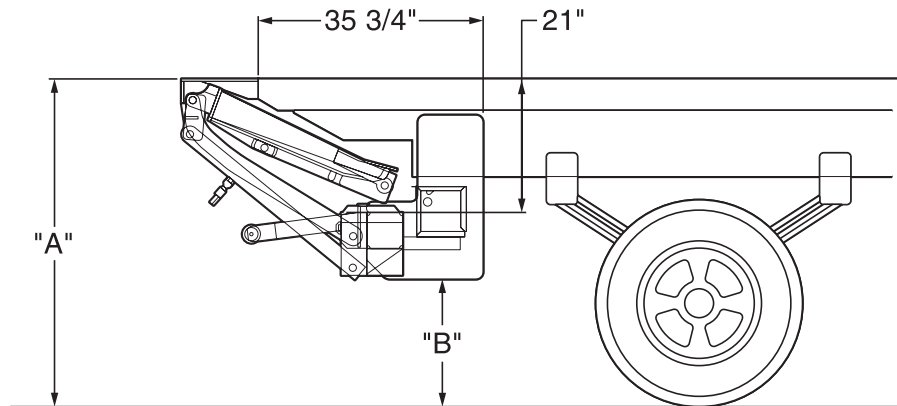

ANTHONY LIFTGATES, INC.®

Anthony Liftgates, Inc.
1037 W. Howard Street
P.O. Box 615
Pontiac, IL 61764-0615
Phone: 815.842.3383
Fax: 815.844.3612
Toll Free: 800.482.0003
www.anthonyliftgates.com