

# Anthony AST Tuckunder SF™ Hydraulic Liftgates®



*Lifting Capacities: 1,500 lb. 2,000lb. 2,500 lb. 3,000 lb.*



*Shown with optional maximum-duty  
2-step steel dock bumpers.*

*Prepped with  
Steel Shot Process*



*(See page 3)*

**ANTHONY**  
LIFTGATES, INC.®

## Anthony: Industry Leader

Anthony Liftgates has been the driving force in the industry since 1941, producing innovative designs and quality products for trucks of all sizes. Our factory support is unmatched in the industry, providing dealers and their customers coast to coast with prompt delivery of products, parts orders, and custom engineering requests. Looking for a product you can stake your reputation on? Anthony Liftgates offers a wide range of models backed by the best warranty in the business. For performance, dependability, and value, Anthony delivers the complete package for every application!

## Features that Lead the Industry:

### Hydraulic System

The factory-filled **closed hydraulic system** protects against outside contaminants and moisture. The **steel pump enclosure** protects components from damage by impact, debris, and weather. Hingeless lid design eliminates corroded hinge problems. (Pump shown for Power-Down models)



Used at critical pivot points, these bushings extend pin and arm life, while eliminating routine lubrication and increasing resale value.

### LIFETIME WARRANTY Service-Free™ Bushings — An Anthony First



Used at critical pivot points, these bushings extend pin and arm life, while eliminating routine lubrication and increasing resale value.

### Anthony Exclusive, ZLC- Zero Leak Concept™



The use of machined fittings, SAE "O" ring and JIC hydraulic connections, along with factory installed multi-purpose ATF, mean you'll have long, trouble-free service with no aggravating and costly leaks.

### E-Z Mount™ Installation

All Anthony AST models are factory assembled, tested, and energized to assure the highest quality performance standards. They ship completely assembled on skids for fast, clean, easy installation; and Anthony's



pre-notched center mark template ensures accurate placement of the floor extension and precise spacing for all welds. E-Z Mount installations provide the fastest installation times of any competitive models.

### Positive Electrical Connections

Heat-shrink siliconed wire con-



nections seal out moisture, and anti-rotation terminals insure rugged circuit protection.

### Low Operating Pressure, Larger-Bore Hydraulic Cylinder

The double-weight hydraulic cylinder allows operation at a lower pressure to increase the



life of the entire hydraulic system, batteries, and electrical components. The extra thick chrome plated piston rod and the piston cylinder wear rings further extend Service-Free operation

### Marine-Duty Toggle Switch

Heavy-duty polyethylene switch box with a **potted switch** inside provide the best all-weather



protection available.

Terminals and connections are permanently separated and sealed to eliminate corrosion and electrical failure. (Steel switch guard optional)



## Quality Standard Features:

### **Pressure Compensated Flow Valve**

Provides constant and controlled lowering speed of the platform, loaded or unloaded, and prevents platform from "free-fall" under certain hydraulic failures.

### **Chrome Plated Piston Rod**

Keeps exposed surface free from rust and contamination to protect seals and extend cylinder life.

### **Piston Cylinder Wear Rings**

Prevent scoring by maintaining piston/cylinder wall tolerances.

### **Relief Valve**

Prevents overloading during lifting cycle.

### **Factory Installed Hydraulic Fluid**

Prevents contamination during installation with proper hydraulic fluid.

### **Low Operating Pressure**

Extends service life of power unit, hoses, cylinder seals and battery.

### **3/16" Formed Diamond Tread Floor Extension**

Provides rugged and attractive surface.

### **Platform Roller Wheel Opener**

Prevents metal-on-metal damage and provides smooth folding and unfolding.

### **Spring-Assist Platform**

Dual torsion springs provide easy opening and closing, assist springs on flip section. (Single spring on lowboy models.)

### **Heavy-Duty Sandwiched Hinge Plate**

Maintains platform stability under heavy load conditions.



### **Shot Blast / Powder Coat**

All platforms and weldments are prepped with steel shot and then powder coated for a finish that provides the best surface appearance, impact resistance, coating adhesion, and wear resistance.

### **Exclusive 2 + 2 Warranty**

2 years on mechanical structure, 2 years on electrical / hydraulic systems, parts and labor. All Anthony Tuckunder liftgates are serial numbered and computer logged for quick factory service identification, warranty and repair information.

### **Circuit Protection Device (200 Amp.)**

Protects truck wiring and power system in the event of a "dead short".

### **Yellow Di-Chromate Plated Pins**

Used at all pivot points, these pins provide long-life protection from rust, road salt, and moisture.

\* NOTICE: Some models of Anthony Liftgates may be provided with step devices to assist the ingress and egress of the truck or trailer rear. These devices are NOT to be considered ALL INCLUSIVE of any requirements or guidelines regarding proper ingress and egress of trucks and trailers. These items are provided as only an added feature for installers to help simplify the meeting of possible ingress and egress requirements. As there are many variables in truck sizes and shapes, it is the installer's responsibility to determine proper ingress and egress requirements, such as steps and hand grips, for each vehicle receiving an Anthony liftgate.



AST in stored/travel position, shown with optional dock bumpers



Recessed Toggle Switch (optional)



Optional 5 & 12 ton Pintle Hook Brackets



Optional maximum duty dock bumper with third step add-on



Easy access and highly visible, heavy-duty Latch Pin Assembly positively secures gate in closed position. This Anthony *standard* feature is the strongest and most visible latch in the industry.

## Available Models, Platforms and Capacities

MODEL	Lifting Capacity (lbs.)	Bed Height Min-Max	Platform Load Area and Ramp	Shipping Wt. (lbs.)
AST-1500-SF	1,500	42"-57"	80" x 38"+5"	838
AST-2000-SF	2,000	42"-57"	80" x 38"+5"	855
AST-2500-SF	2,500	42"-57"	80" x 38"+5"	889
AST-3000-SF	3,000	42"-57"	80" x 38"+5"	934
<b>Lowboy Models</b>				
ASTL-1800-SF	1,800	36"-57"	80" x 32"+5"	770
ASTL-2500-SF	2,500	36"-57"	80" x 32"+5"	802

All AST Tuckunder SF series meet or exceed all TMC specifications.

All models shipped with standard ramp ride platform.

Anthony Liftgates Inc. reserves the right to make technical changes for product improvement. Specifications and materials subject to change without notice. Photos and illustrations may show optional equipment.

## Options

- Hand-held control (on coiled cord) with plug and socket
- Maximum duty 2-step dock bumper
- Third step add-on extension for bumpers
- Street-side control
- Flush-mount control inside van
- ICC bumper
- Rubber bumper pads
- Power down
- Steel guard for toggle switch control box
- Flush-mount toggle switches
- 5 & 12 ton pintle hook brackets
- Lift alert audible alarm
- Ignition cut-off switch
- 102" wide floor extension —  $\frac{3}{16}$ "
- $\frac{1}{4}$ " Heavy-duty floor extension for 96" and 102" wide extensions
- 80" X 48" wedge platform
- Walkramp capability
- Wireless remote control
- LVC - Anthony's Low Voltage Control has a programmable security control, cycle counter, and alerts the operator when batteries are running low.



## Mounting Requirements

A Bed Height Adapter Frame	B Bed to top of Clearance	C Mounting Plate
36" - 41"	15 $\frac{3}{4}$ "	29"
42" - 49"	19"	24 $\frac{1}{4}$ "
50" - 51"	20"	23 $\frac{3}{4}$ "
52" - 53"	21"	23 $\frac{1}{4}$ "
54" - 55"	22"	22 $\frac{5}{8}$ "
56" - 57"	23"	22 $\frac{1}{2}$ "

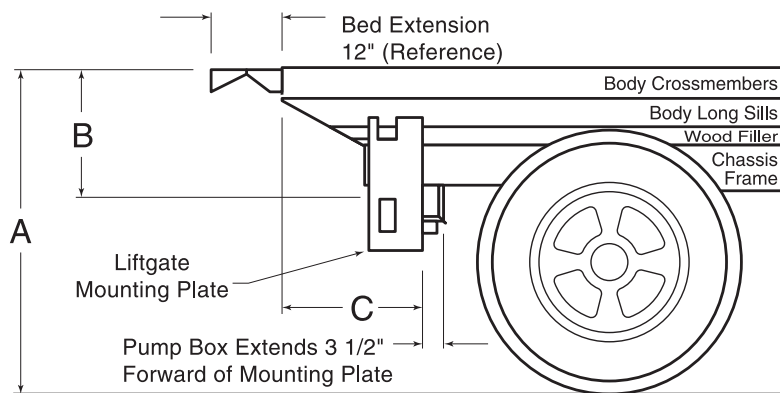

## ANTHONY LIFTGATES, INC.®

Anthony Liftgates, Inc.  
1037 W. Howard Street  
P.O. Box 615  
Pontiac, IL 61764-0615  
Phone: 815.842.3383  
Fax: 815.844.3612  
Toll Free: 800.482.0003  
www.anthonyliftgates.com